

Heavy-duty Desktop Series

EFORT

The heavy-duty desktop robot series has a strong load capacity and a wide range of work, and is precise, efficient, flexible and compact, which can significantly improve production efficiency.

01 Highlights

The heavy-duty desktop series includes multiple versions with load/work ranges of 8kg/1.3m, 10kg/1.1m, and 12kg/0.9m, suitable for 3C, Automotive components, PV Solar, Li-ion battery, general and other industries.



It features high precision with a design that combines high rigidity and lightweight construction, achieving a repeat positioning accuracy of up to 0.02mm.



The robot has a compact structure with a fully enclosed IP67 design, occupying only 260mm*260mm of space and enabling deployment in narrow and confined spaces.



It also offers high efficiency with a standard door cycle time of 0.42s, and strong load capacity and wide work range.



The robot wrist has a higher torque, inertia, and rigidity, ensuring high performance.

02 Main Applications

Handling Operations, Testing, Assembling, Grinding, Polishing, Arc welding.



EFORT INTELLIGENT EQUIPMENT CO.,LTD.

PHONE: (00 86) 400-052-8877

ADDRESS: No.96 East Wanchun Road, China(Anhui) Pilot Free Trade Zone Wuhu Area, Wuhu, Anhui Province, China

WWW.EFORT.COM.CN

ER8-1300

EFORT

ER8-1300,
Maxium payload 8 kg with maxium reach 1291 mm.

■ **Applications**

It can be used in handling operations(machine tending), sorting, assembling, grinding, polishing, Arc welding, etc.

■ **Industries**

Suitable for PCB, 3C, plastic, metal parts and other industries.

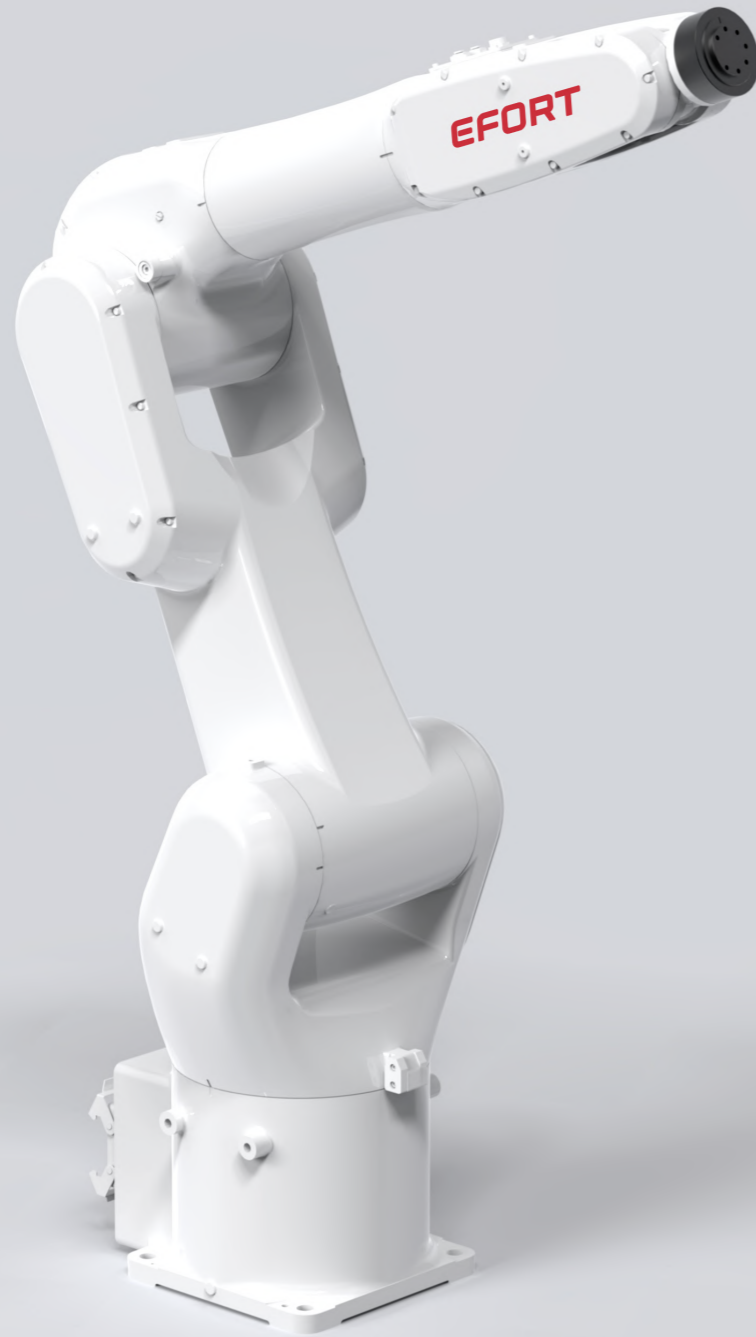

SPECIFICATIONS

Model	ER8-1300	
Type	Articulated	
Controlled axes	6 Axes	
Max. payload on wrist	8 kg	
Repeatability	±0.03 mm	
Robot weight	80 kg	
Reach	1291 mm	
Robot IP grade	IP65 / IP67 (Wrist)	
Cabinet IP grade	IP20 / IP54 (Optional)	
Drive mode	AC servo drive	
Installation	Floor, Upside-down, Wall	
Installation enviroment	Ambient temperature	0~45 °C
	Ambient humidity	RH≤80% (No dew nor frost allowed)
	Vibration acceleration	4.9 m/s ² (<0.5 G)

Allowable load moment at wrist	J4	25 N · m
	J5	25 N · m
	J6	12 N · m
Allowable load inertia at wrist	J4	0.78 kg · m ²
	J5	0.78 kg · m ²
	J6	0.3 kg · m ²
Maximum speed	J1	230°/sec
	J2	190°/sec
	J3	240°/sec
	J4	500°/sec
	J5	420°/sec
	J6	720°/sec
Motion range	J1	± 170°
	J2	+100°/-130°
	J3	+193°/-75°
	J4	± 190°
	J5	± 120°
	J6	± 360°

OPERATING SPACE

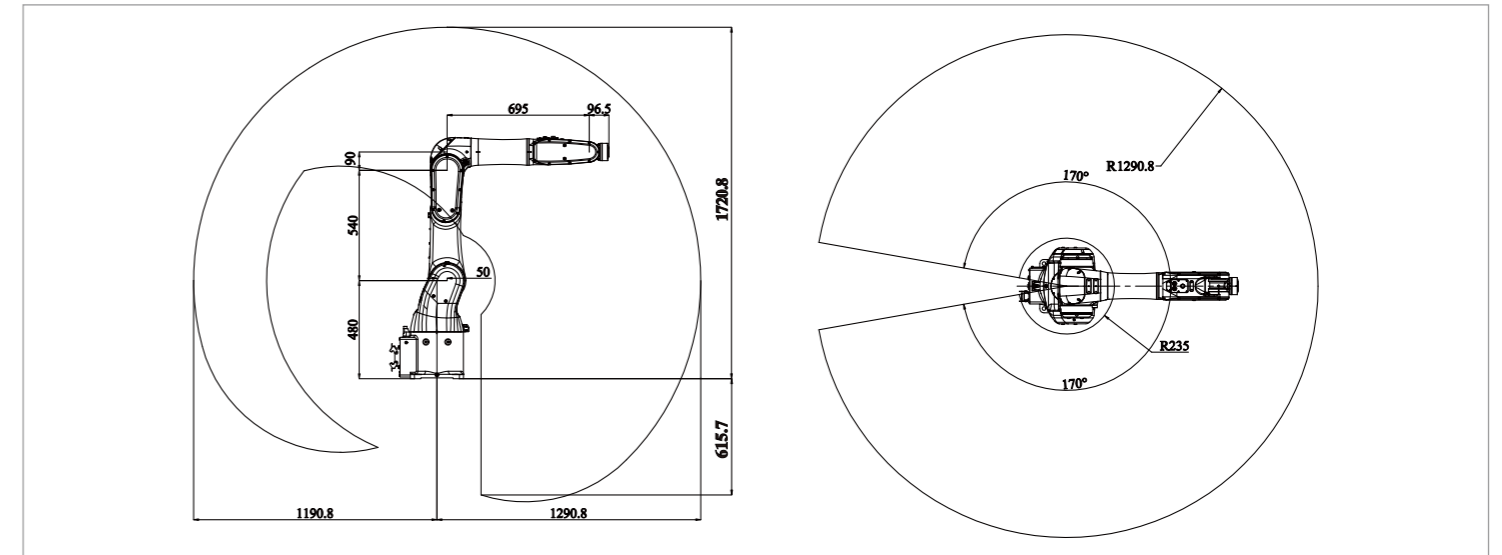

BASE MOUNTING SIZE

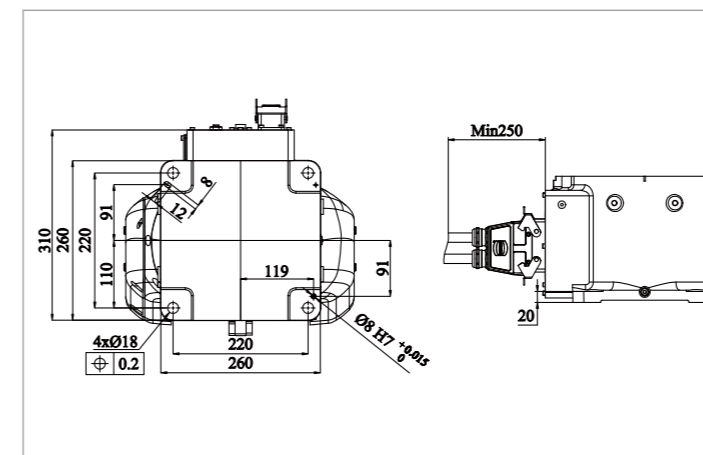

END FLANGE MOUNTING SIZE

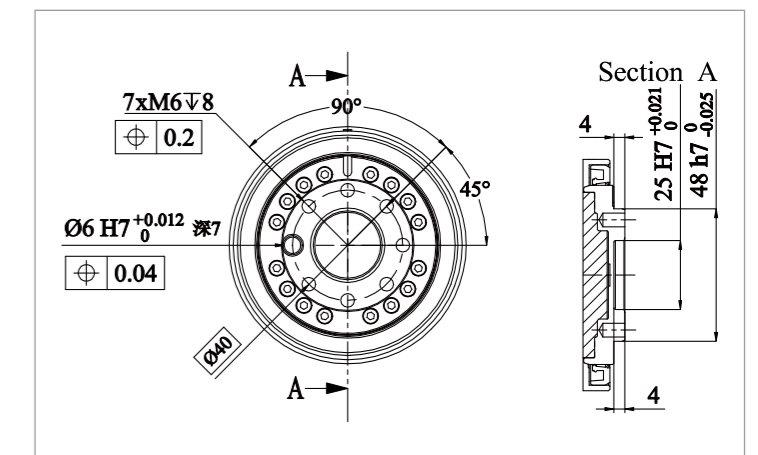

EFORT INTELLIGENT EQUIPMENT CO.,LTD.

PHONE: (00 86) 400-052-8877

ADDRESS: No.96 East Wanchun Road, China(Anhui) Pilot

Free Trade Zone Wuhu Area, Wuhu, Anhui Province, China

WWW.EFORT.COM.CN

ER10-1100

EFORT

ER10-1100,
Maxium payload 10 kg with maxium reach 1142 mm.

■ **Applications**

It can be used in handling operations(machine tending), sorting, assembling, grinding, polishing, Arc welding,etc.

■ **Industries**

Suitable for PCB, 3C, plastic, metal parts and other industries.

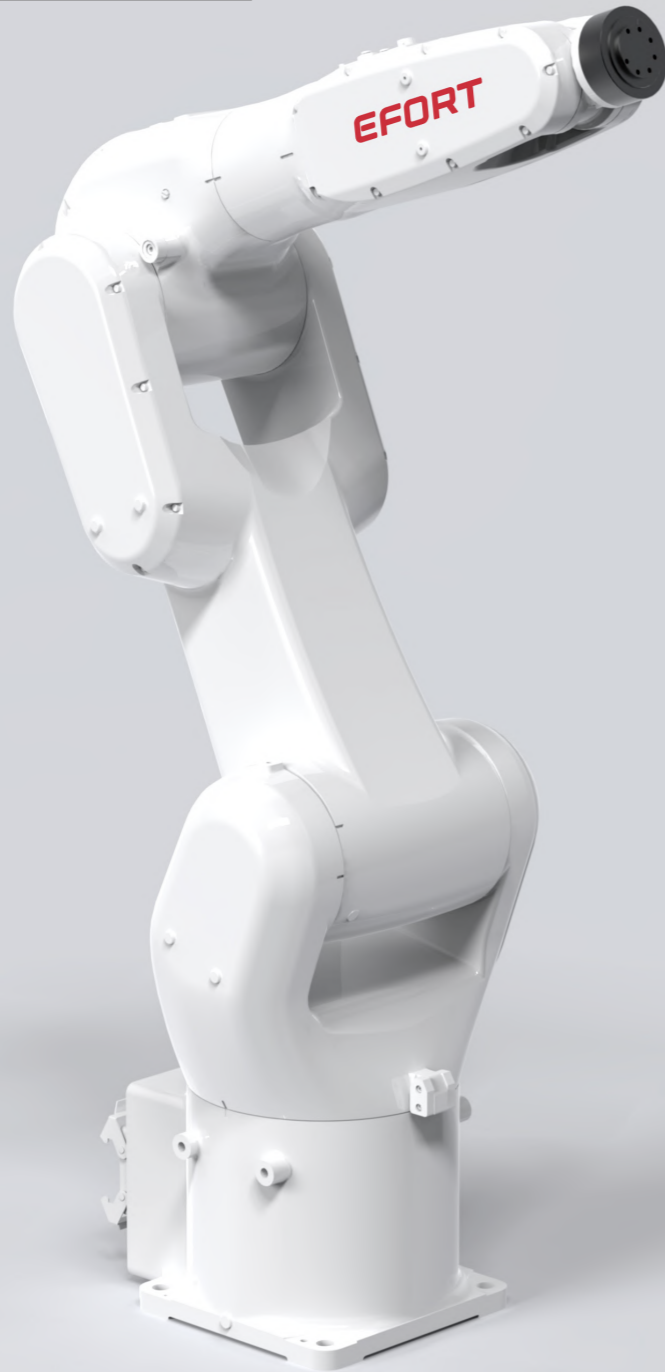

SPECIFICATIONS

Model	ER10-1100	
Type	Articulated	
Controlled axes	6 Axes	
Max. payload on wrist	10 kg	
Repeatability	± 0.025 mm	
Robot weight	78 kg	
Reach	1142 mm	
Robot IP grade	IP65 / IP67 (Wrist)	
Cabinet IP grade	IP20 / IP54 (Optional)	
Drive mode	AC servo drive	
Installation	Floor, Upside-down, Wall	
Installation enviroment	Ambient temperature	0~45 °C
	Ambient humidity	RH≤80% (No dew nor frost allowed)
	Vibration acceleration	4.9 m/s ² (< 0.5 G)

Allowable load moment at wrist	J4	25 N · m
	J5	25 N · m
	J6	12 N · m
Allowable load inertia at wrist	J4	0.78 kg · m ²
	J5	0.78 kg · m ²
	J6	0.3 kg · m ²
Maximum speed	J1	230°/sec
	J2	225°/sec
	J3	330°/sec
	J4	500°/sec
	J5	420°/sec
	J6	720°/sec
Motion range	J1	± 170°
	J2	+100°/-130°
	J3	+193°/-75°
	J4	± 190°
	J5	± 120°
	J6	± 360°

OPERATING SPACE

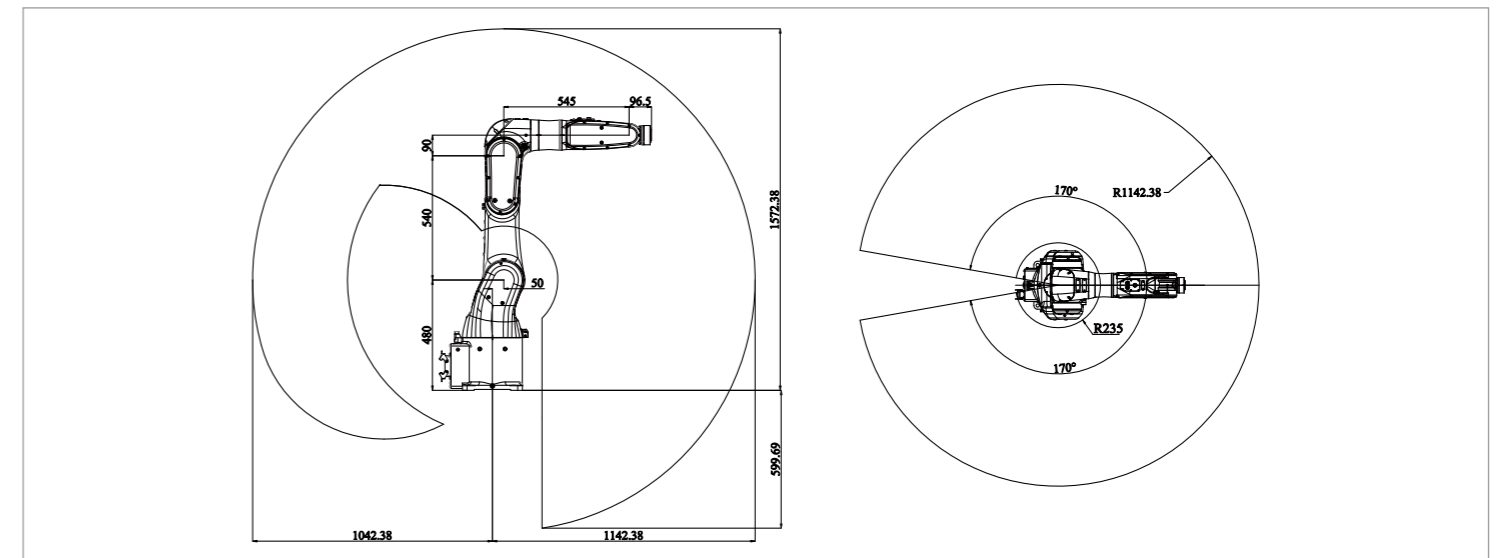

BASE MOUNTING SIZE

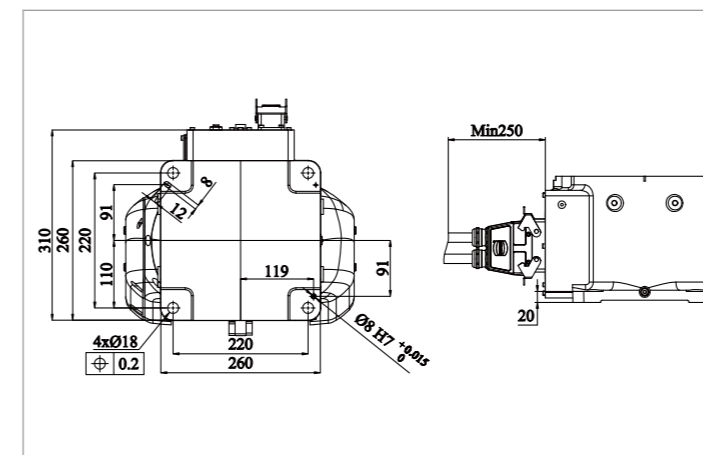

END FLANGE MOUNTING SIZE

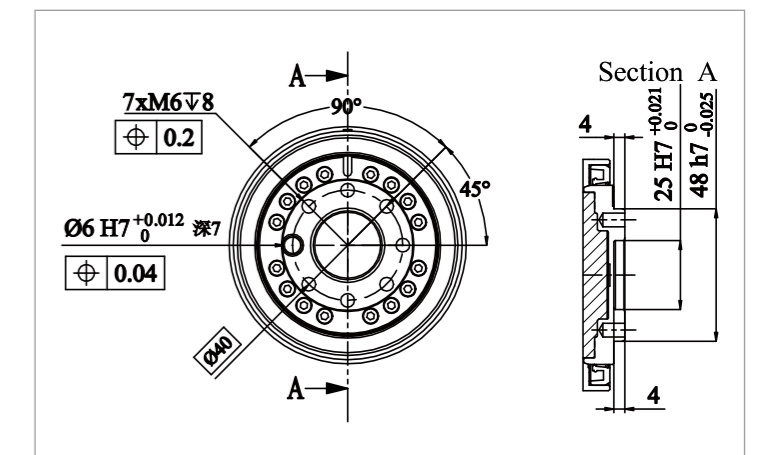

EFORT INTELLIGENT EQUIPMENT CO.,LTD.

PHONE: (00 86) 400-052-8877

ADDRESS: No.96 East Wanchun Road, China(Anhui) Pilot Free Trade Zone Wuhu Area, Wuhu, Anhui Province, China

WWW.EFORT.COM.CN

ER12-900

EFORT

ER12-900,
Maxium payload 12 kg with maxium reach 944 mm.

■ **Applications**

It can be used in handling operations(machine tending), sorting, assembling, grinding, polishing, Arc welding, etc.

■ **Industries**

Suitable for PCB, 3C, plastic, metal parts and other industries.

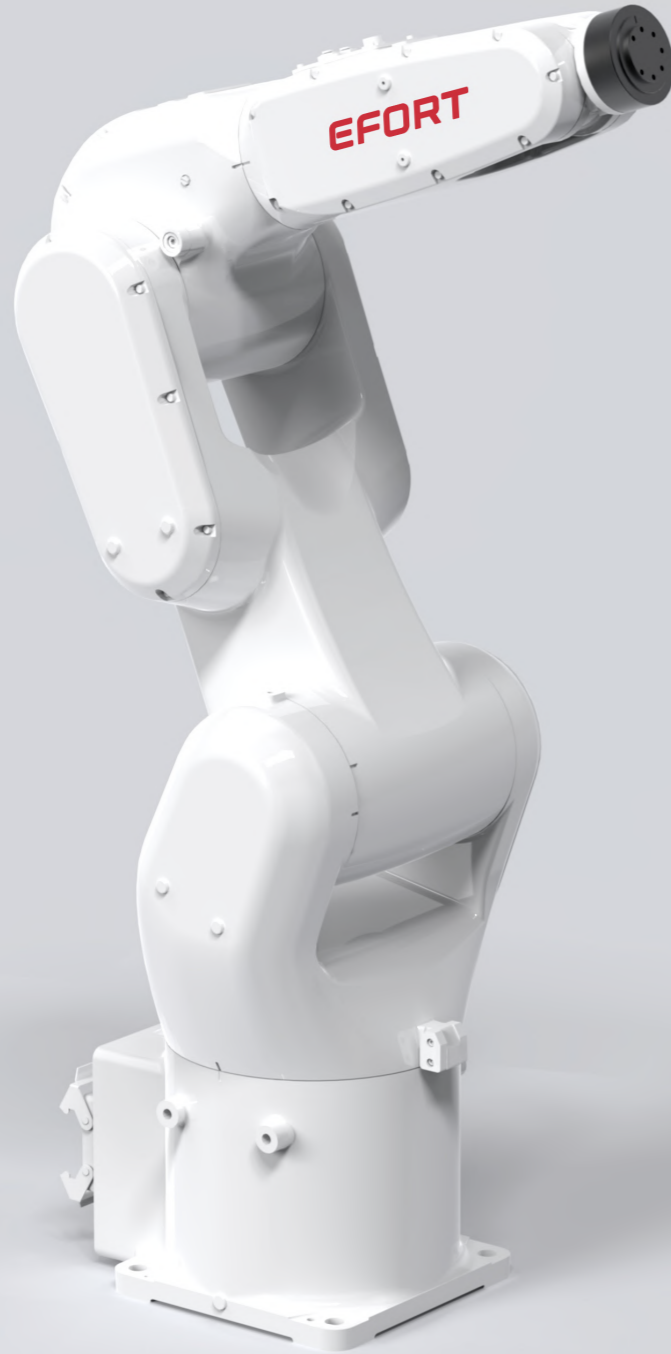

SPECIFICATIONS

Model	ER12-900	
Type	Articulated	
Controlled axes	6 Axes	
Max. payload on wrist	12 kg	
Repeatability	±0.02 mm	
Robot weight	75 kg	
Reach	944 mm	
Robot IP grade	IP65 / IP67 (Wrist)	
Cabinet IP grade	IP20 / IP54 (Optional)	
Drive mode	AC servo drive	
Installation	Floor, Upside-down, Wall	
Installation enviroment	Ambient temperature	0~45 °C
	Ambient humidity	RH≤80% (No dew nor frost allowed)
	Vibration acceleration	4.9 m/s ² (<0.5 G)

Allowable load moment at wrist	J4	25 N · m
	J5	25 N · m
	J6	12 N · m
Allowable load inertia at wrist	J4	0.78 kg · m ²
	J5	0.78 kg · m ²
	J6	0.3 kg · m ²
Maximum speed	J1	245°/sec
	J2	225°/sec
	J3	330°/sec
	J4	500°/sec
	J5	420°/sec
	J6	720°/sec
Motion range	J1	± 170°
	J2	+100°/-130°
	J3	+193°/-75°
	J4	± 190°
	J5	± 120°
	J6	± 360°

OPERATING SPACE

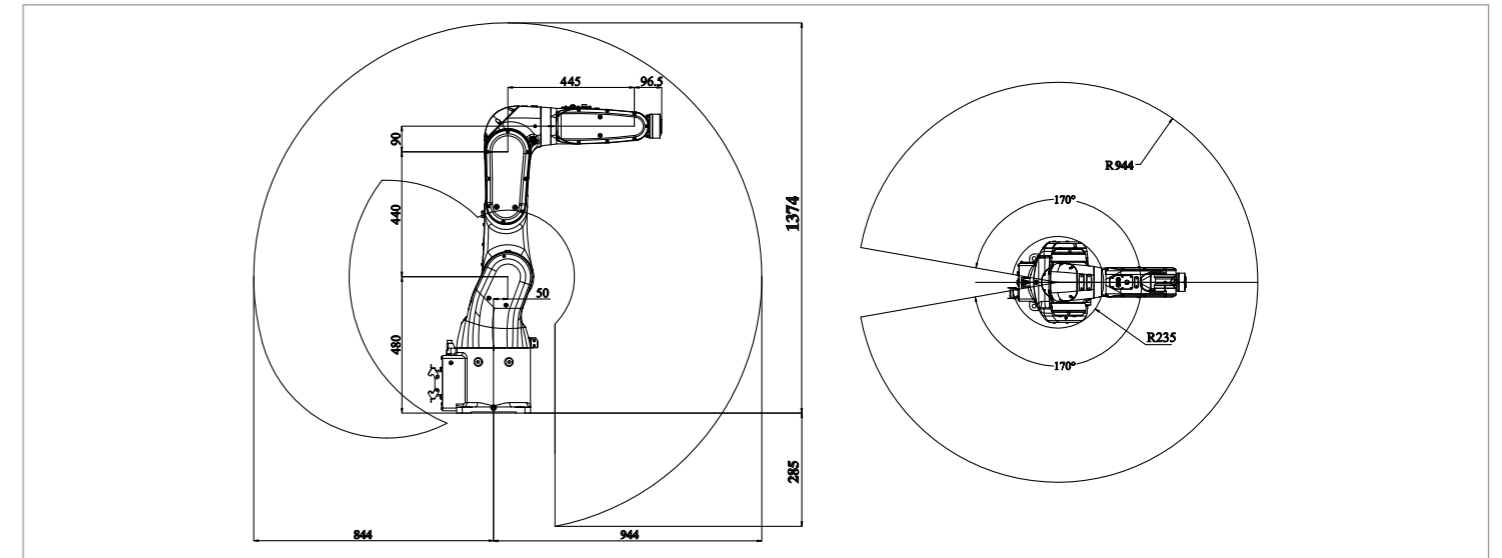

BASE MOUNTING SIZE

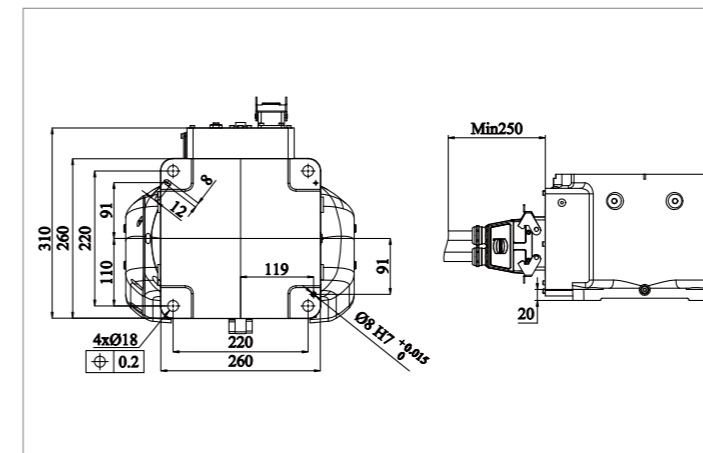

END FLANGE MOUNTING SIZE

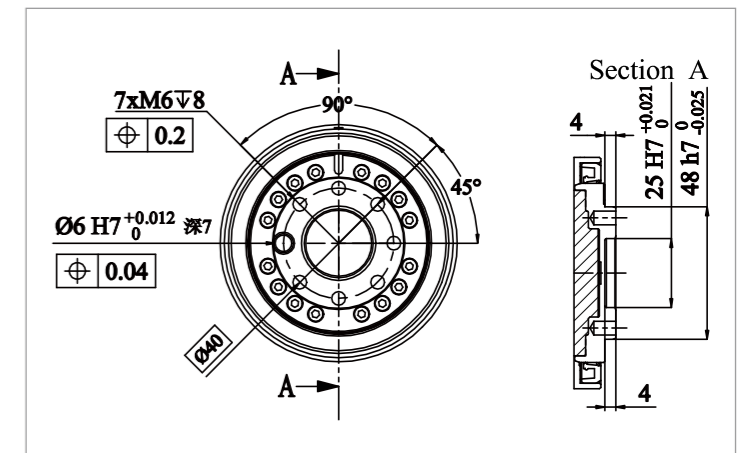

EFORT INTELLIGENT EQUIPMENT CO.,LTD.

PHONE: (00 86) 400-052-8877

ADDRESS: No.96 East Wanchun Road, China(Anhui) Pilot

Free Trade Zone Wuhu Area, Wuhu, Anhui Province, China

WWW.EFORT.COM.CN