

Medium-Large Payloads Robot

ER50-2100

ER50-2100 is a medium payloads robot.
Maxium payload 50 kg with maxium reach 2146 mm.

Highlights

Thanks to the high stiffness structure, with high-speed intelligent palletizing application software, the takt is improved by 20%, bring customers more efficiency;
Multiple specific application software could be integrated, with soft PLC and a variety of field bus interface, which enable customers easily face various application challenges;
High performance collision detection function helps safety realization.

Applications

It can be widely used in handling, polishing, palletizing, machine tending and other applications.

Industries

Suitable for auto parts, photovoltaic, food and beverage, building materials, logistics and warehousing and other industries.



EFORT

SPECIFICATIONS

Model	ER50-2100	
Type	Articulated Type	
Controlled Axes	6 Axes	
Wrist Payload	50 kg	
Repeatability	± 0.06 mm	
Robot Weight	550 kg	
Reach	2146 mm	
Robot IP Grade	IP54/IP67 (Wrist)	
Cabinet IP Grade	IP54	
Drive Method	Electric servo drive by AC servo motor	
Installation	Floor, Wall mount	
Environment Requirements	Ambient Temperature	0~45 °C
	Humidity	< 80%/40°C (No Condensation)
	Vibration Acceleration	4.9 m/s ² (< 0.5 G)

Allowable Torque	J4	182 N.m
	J5	182 N.m
	J6	120 N.m
Allowable Moment of Inertia	J4	12.68 kg.m ²
	J5	12.68 kg.m ²
	J6	10 kg.m ²
Maximum Speed	J1	170°/sec
	J2	170°/sec
	J3	170°/sec
	J4	270°/sec
	J5	270°/sec
	J6	365°/sec
Motion Range	J1	± 180°
	J2	+70°/-130°
	J3	+175°/-80°
	J4	± 360°
	J5	± 115°
	J6	± 450°

OPERATING SPACE

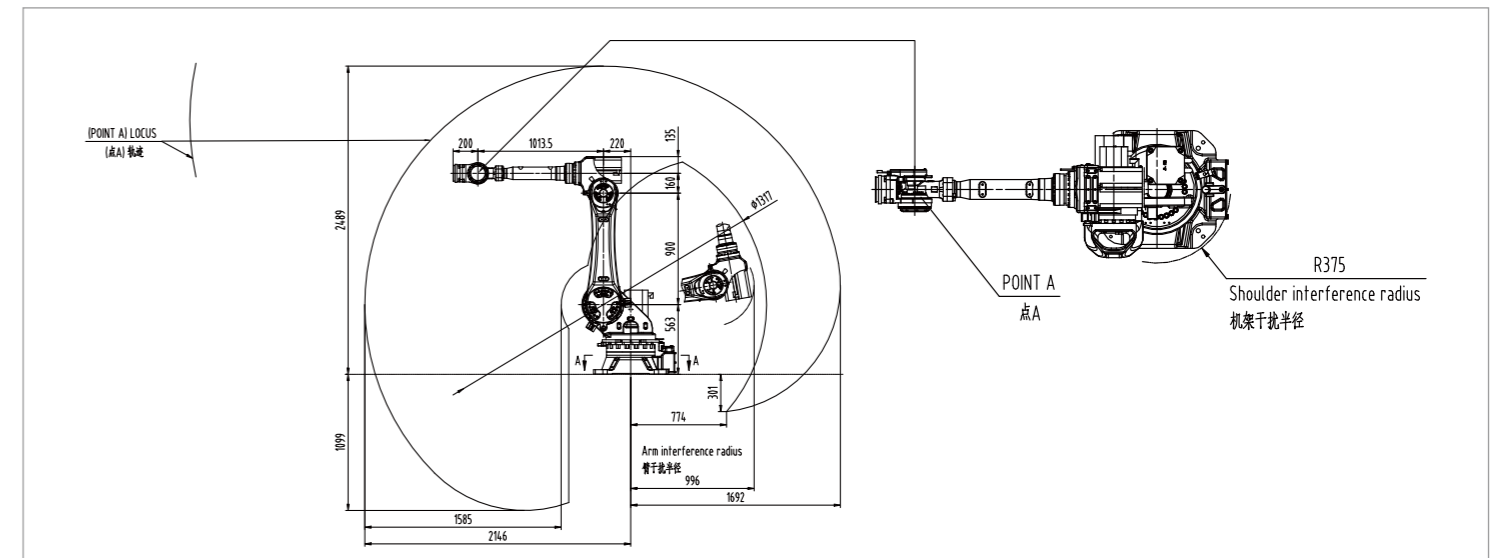

BASE MOUNTING SIZE

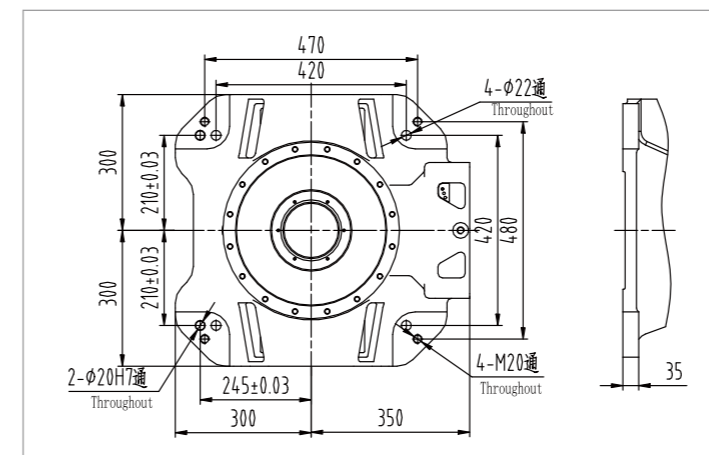

END FLANGE MOUNTING SIZE

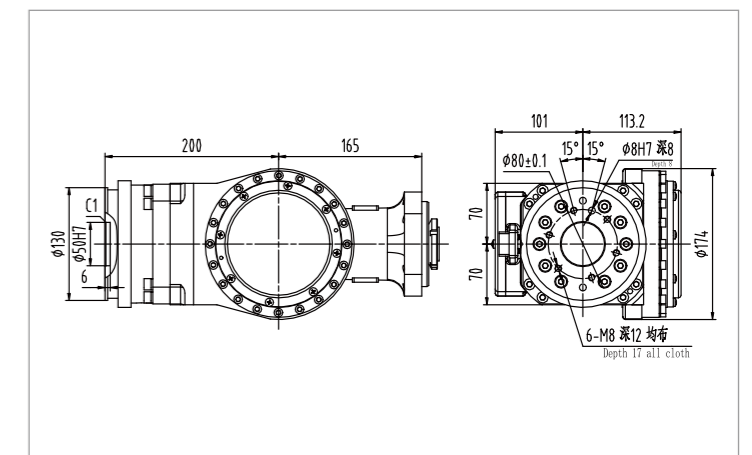

EFORT INTELLIGENT EQUIPMENT CO.,LTD.

PHONE: (00 86) 400-052-8877
ADDRESS: No.96 East WanChun Road, JiuJiang Economic Development Zone, Wuhu, Anhui, China
WWW.EFORT.COM.CN